

Fiberglass Flagpoles

Fiberglass
Architectural
Outrigger
Flagpoles

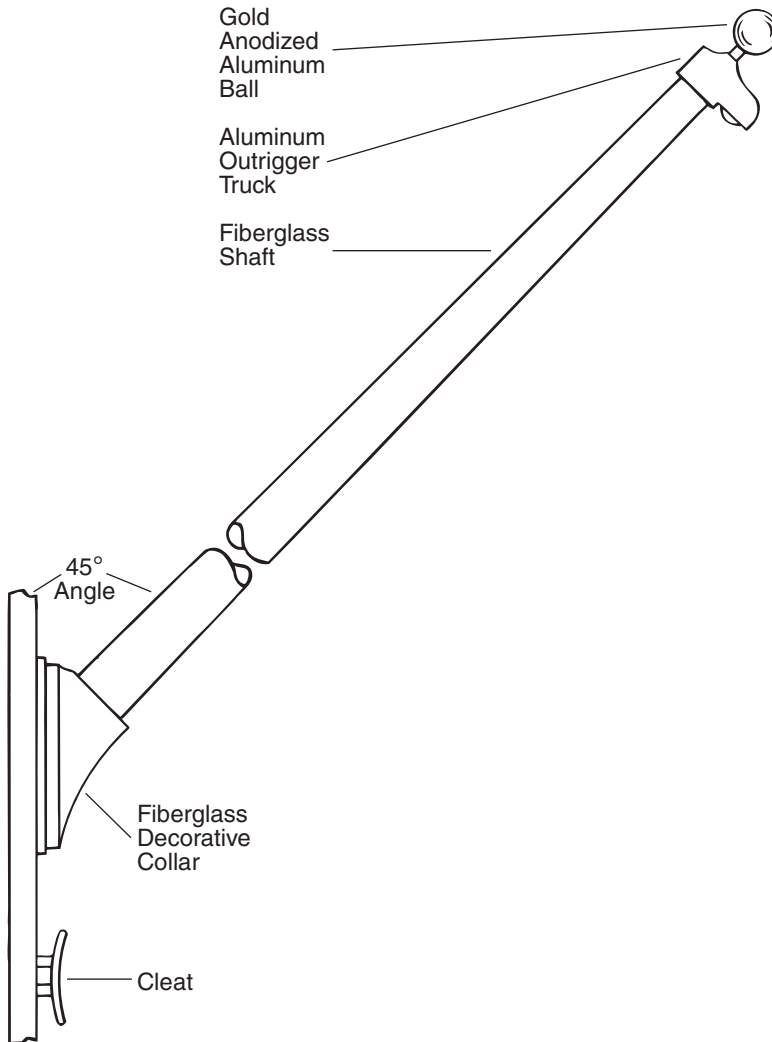

Aluminum Outrigger Truck

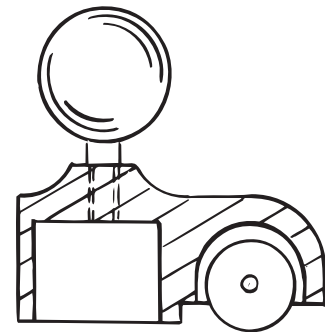

Aluminum Wall Bracket

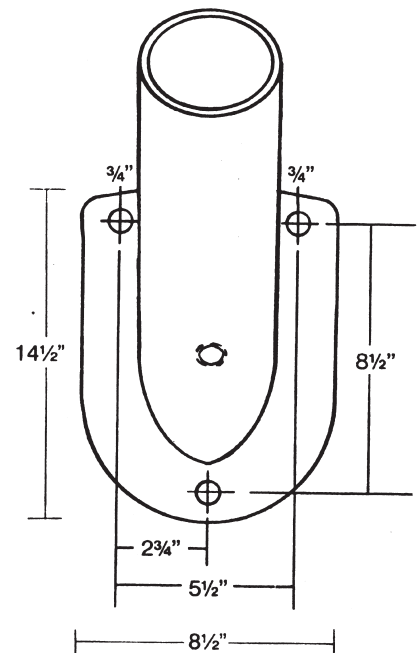

Wall Mount Detail

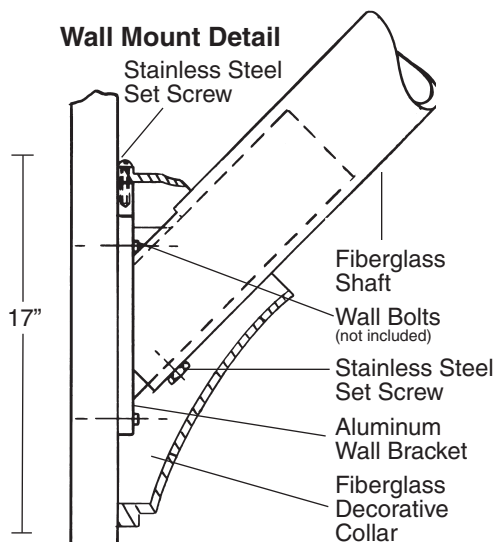

SPECIFICATIONS

Provide a Fiberglass Reinforced Plastic (FRP) 45° Architectural Outrigger Flagpole Model #OR _____ AR as manufactured by PLP Composite Technologies, Inc., Fitzwilliam, NH 03447.

The flagpole shall have an overall length of _____ feet. The butt diameter shall be _____ inches and the top diameter _____ inches. The pole weight shall be approximately _____ lbs. with a total shipping weight of _____ lbs.

The flagpole shall be manufactured of fiberglass woven roving and polyester resin with 75% of the reinforcing fibers oriented in the axial plane for maximum stiffness and 25% in the radial plane for required hoop strength. Load calculations shall be based on AASHTO and NAAMM standards with the pole designed with a two to one safety factor for 125 m.p.h. winds, unflagged with a 1.3 gust factor.

The pole shall have an ENTASIS taper and shall be void of any vertical mold seams.

The pole shall be sanded smooth and coated with a high gloss Aliphatic Polyurea coating system based on Dual Cure chemistry, providing extended UV protection and weatherability.

The color of the flagpole shall be:

Standard white, bronze, black, or other, as specified _____. (Select one)

The 45° Architectural Outrigger Flagpole shall be equipped with an aluminum wall bracket and the pole will be assembled onto this according to the manufacturer's instructions using an epoxy paste mixture and set screw provided. The wall bracket shall be covered with a fiberglass decorative collar. Wall bolts are not included.

The 45° Architectural Outrigger Flagpole shall be equipped with PLP standard fittings:

- A 5" gold anodized aluminum ball
- A cast aluminum outrigger truck
- #10 polyester halyard
- 8.5" nylon cleat
- Brass swivel snaps with vinyl covers
- Aluminum wall bracket onto which the pole is cemented and pinned
- A decorative fiberglass collar

EXCEPTIONS: _____

PROJECT: _____

LOCATION: _____

DATE: _____

Model Number	PLP OR10AR	PLP OR12AR	PLP OR14AR
Length	10'	12'	14'
Butt Diameter	5"	5"	5"
Top Diameter	3"	3"	3"
Pole Weight (lbs.)	24	28	32
Shipping Weight (lbs.)*	59	64	70
Cleat	8.5" Nylon	8.5" Nylon	8.5" Nylon
Ball Diameter	5"	5"	5"
Halyard	#10	#10	#10
Truck	Aluminum	Aluminum	Aluminum
Snaps	Brass Swivel	Brass Swivel	Brass Swivel
Standard Flag Size	4x6	5x8	5x8

* Shipping weight includes weight of packaging and fittings.